

DEPRAG Feed Module (DFM)

DEPRAG
machines unlimited



Smaller, lighter, smarter

The DEPRAG Feed Module DFM is versatile and suitable for both manual and stationary screwdriving applications. Take the workload off your employees with the ergonomic handheld screwdriver with automatic screw feed, which enables easy handling and fatigue-free working. The screwdriving process can be horizontal or vertical, depending on the application. Due to its low weight, the DEPRAG Feed Module is also ideal for stationary applications, whether as an attachment to light-weight robots / cobots or as an integrated feed unit in automated production lines.

- **fatigue-free working**
- **constant pressure force**
- **optimized cycle time**
- **for stationary and manual applications**
- **suitable for lightweight robots**

DEPRAG Feeding Technology

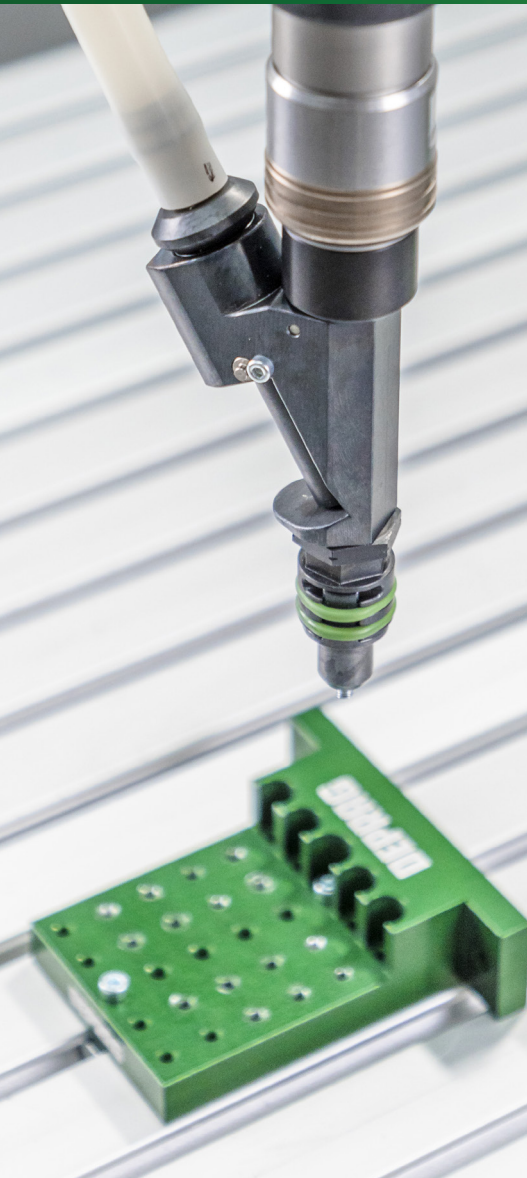

ADVANTAGES

> Ergonomic

Uncomplicated handling and fatigue-free processing due to the integrated bit stroke

> Process reliable

- constant pressure force as a result of the integrated bit stroke
- automatic documentation of processing data

> Efficient

- Optimised cycle time
- automatic feeding of fasteners
 - fast positioning of the screw due to the integrated lock stroke

No PLC required

- integrated sequence controller via the feeding system

> Flexible

- can be combined with electronic or pneumatic drives
- all screwdriving parameters are freely adjustable
- suitable for both stationary and manual applications

> Maintenance friendly

Tool-free quick-change system for bit and positioning sleeves

> Various designs

- straight design with handgrip
- pistol grip design
- version without handgrip for robotic applications
- vacuum design for difficult-to-reach screw positions

> Suitable for lightweight robots

The low weight of the DEPRAG Feed Module makes it ideal for applications which use lightweight robots.

> Complete solution from a single source

The DEPRAG Feed Module can be used in combination with all DEPRAG feeding systems and handling devices.

Straight design with handgrip

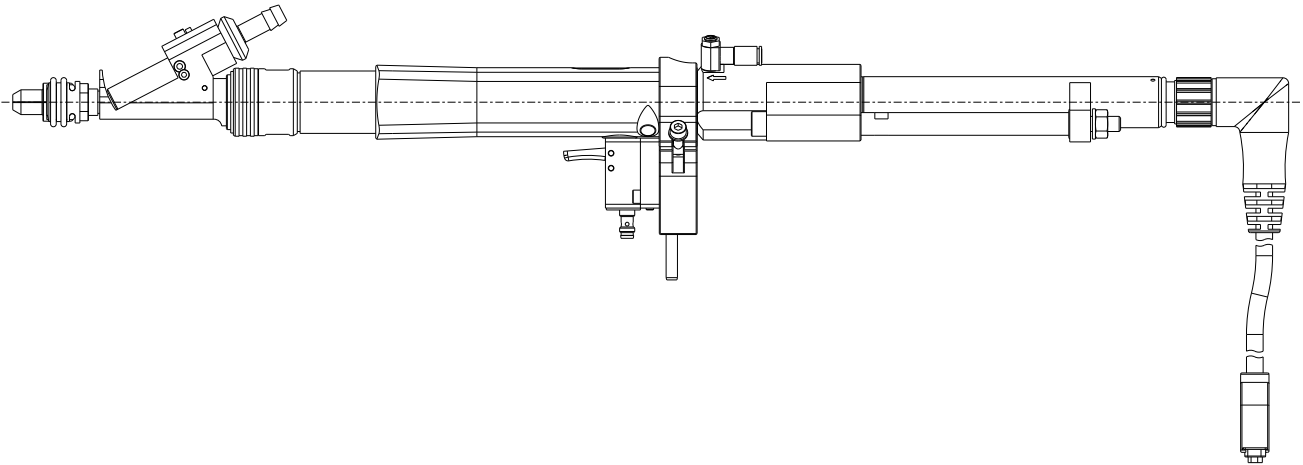

Straight design

- for manual applications
→ vertical screw assemblies

Technical data

Torque range	Nm	0.5 to 18
Screw head- \varnothing max.	mm	14
Shaft- \varnothing max.		M8
Nut max.		M6
Nosepiece length	mm	40 / 80
Free stroke for vacuum	mm	50 / 100

Pistol grip design

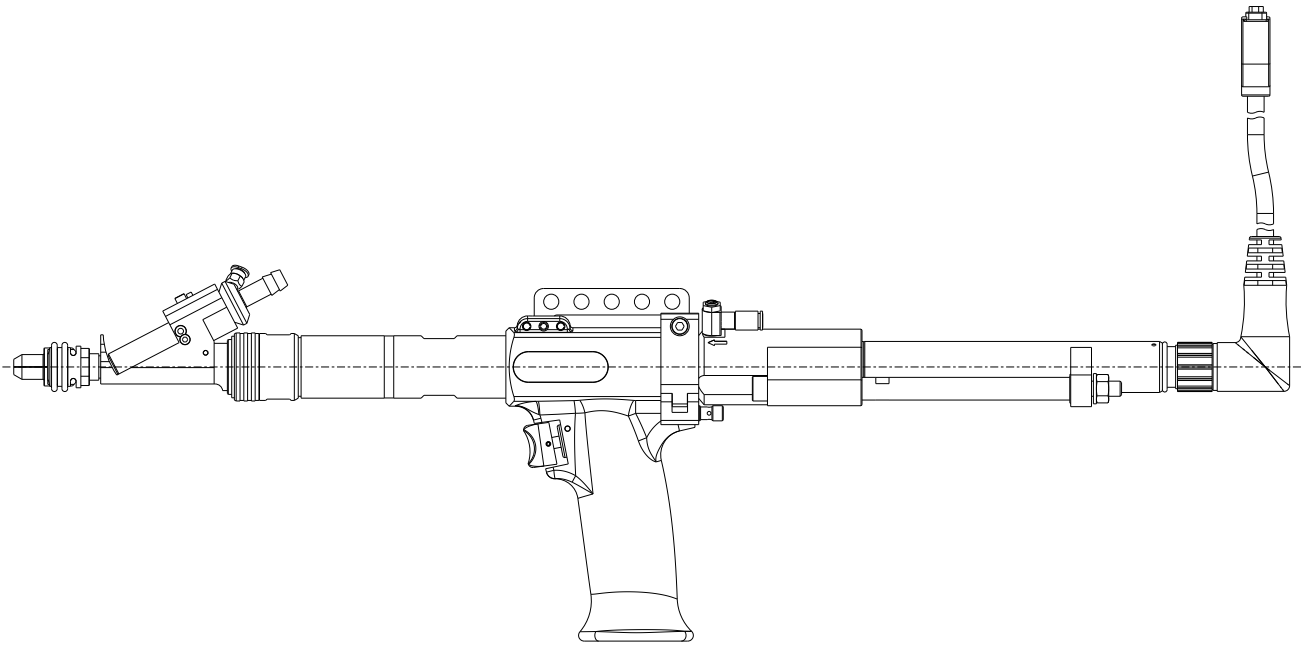

Pistol grip design

- for manual applications
→ horizontal screw assemblies

Technical data

Torque range	Nm	0.5 to 18
Screw head- \varnothing max.	mm	14
Shaft- \varnothing max.		M8
Nut max.		M6
Nosepiece length	mm	40 / 80
Free stroke for vacuum	mm	50 / 100

Version with additional Z-stroke

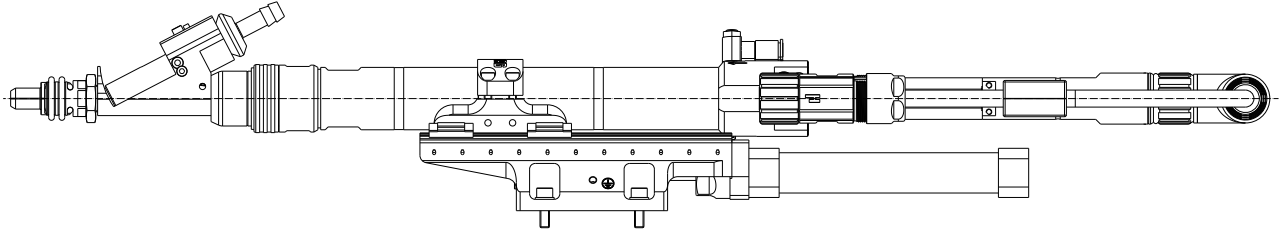

Version with additional Z-stroke

- integrated feed unit replaces customer's Z-axis or robots



Technical data

Torque range	Nm	0.5 to 18
Screw head- \varnothing max.	mm	14
Shaft- \varnothing max.		M8
Nut max.		M6
Nosepiece length	mm	40 / 80
Free stroke for vacuum	mm	50 / 100
Feed stroke	mm	25 / 80

Version with robot flange

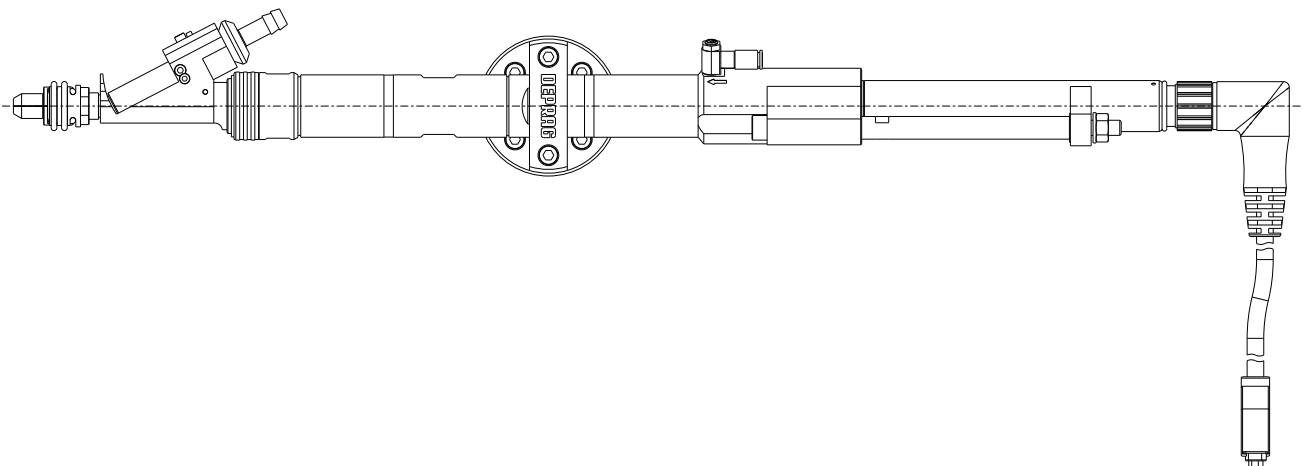

Version without handgrip

- for stationary applications
→ attachment to robots

Technical data

Torque range	Nm	0.5 to 18
Screw head- \varnothing max.	mm	14
Shaft- \varnothing max.		M8
Nut max.		M6
Nosepiece length	mm	40 / 80
Free stroke for vacuum	mm	50 / 100

Version with parallel mounted motor

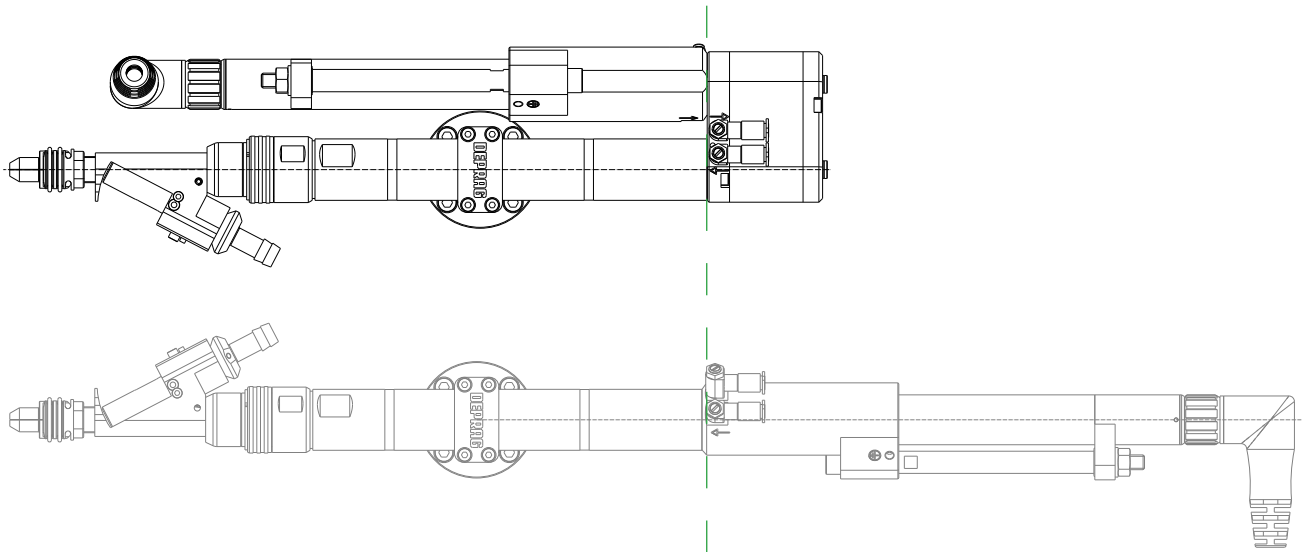

Version with parallel mounted motor

- for confined spaces
- perfectly suited for lightweight robots
- can be combined with all DEPRAG stationary screwdrivers (electronic, electric, pneumatic)

Technical data

Torque range	Nm	1 to 18
Screw head-ø max.	mm	14
Shaft-ø max.		M8
Nut max.		M6
Nosepiece length	mm	40 / 80
Free stroke for vacuum	mm	50 / 100

When using the version with parallel mounted motor, the maximum torque of the screwdriving system is reduced by 5%.



Version as a collaborative system

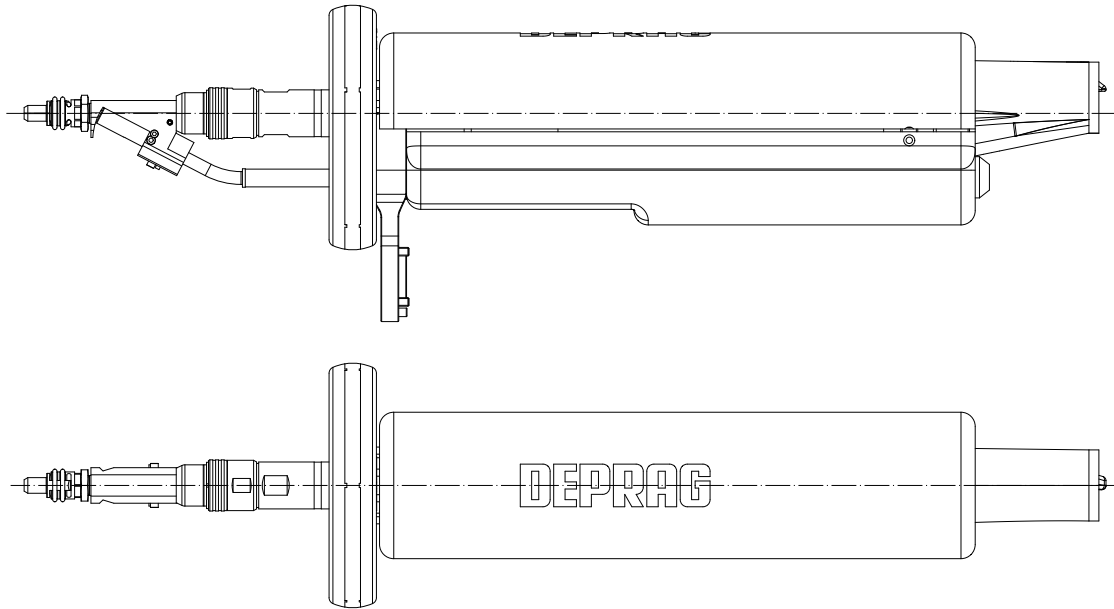

The advantages of the HRC screwdriving system

- **Greater safety for workers:**
Interference or contact? The robot stops immediately. Compliant with DIN ISO/TS 15066.
- **Higher flow rate and less downtime**
The robot only stops in the event of an incident and then automatically continues.
- **Greater flexibility in assembly:**
Humans and robots work in parallel in the same workspace.
- **Less space required:**
No separating protective devices, no unnecessary safety zones.
- **Quick start-up and retrofitting:**
Existing manual workstations or DEPRAG screwdriving units can be converted to an HRC solution.

Technical data

Torque range	Nm	0.5 to 18
Screw head- \varnothing max.	mm	14
Shaft- \varnothing max.		M8
Nut max.		M6
Nosepiece length	mm	40 / 80
Free stroke for vacuum	mm	50 / 100

Example of a complete system – manual version

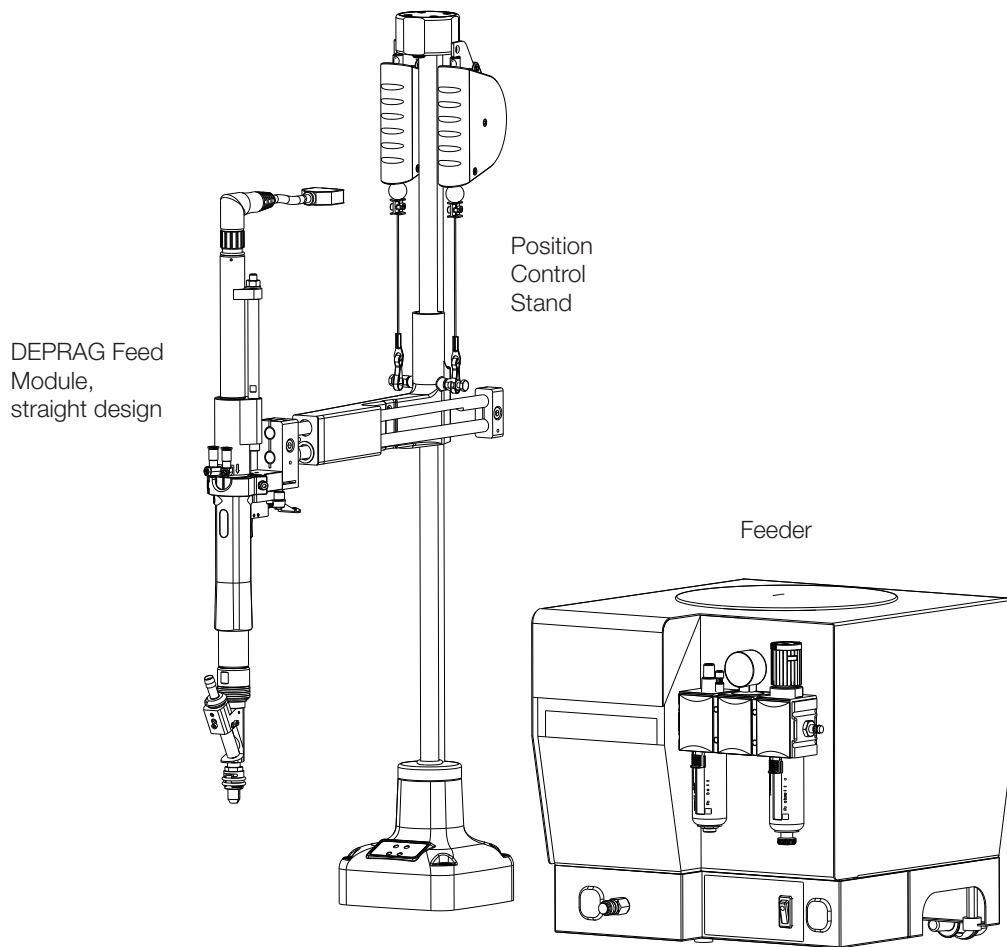

Example of a complete system – stationary version

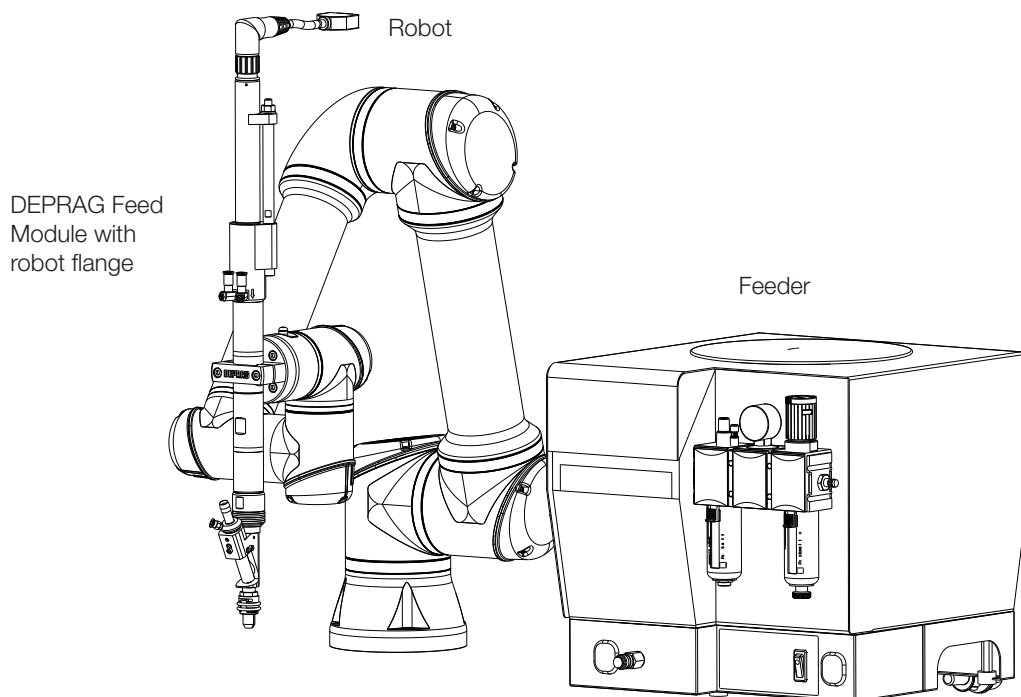

Example of a complete system – collaborative execution

DEPRAG Feed
Module,
collaborative

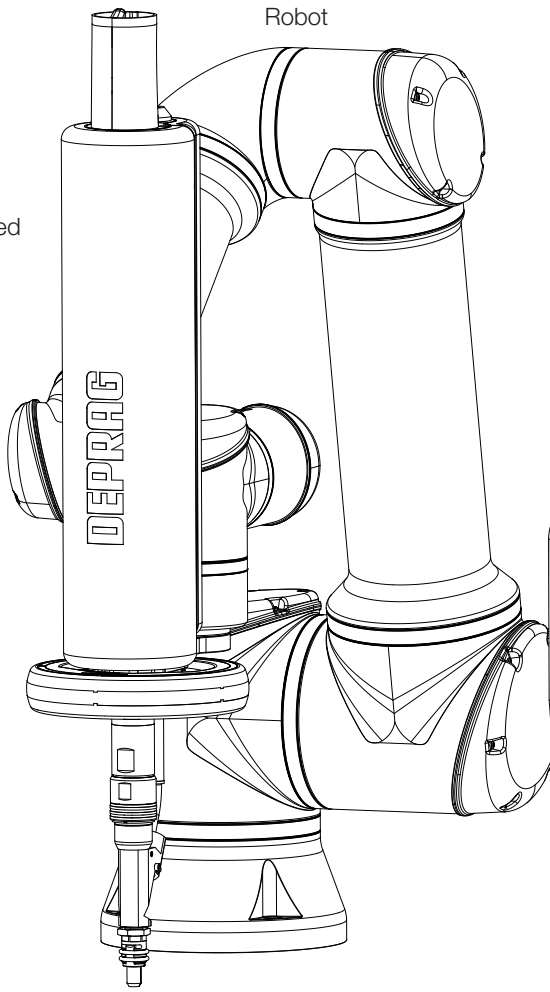

Robot

Feeder

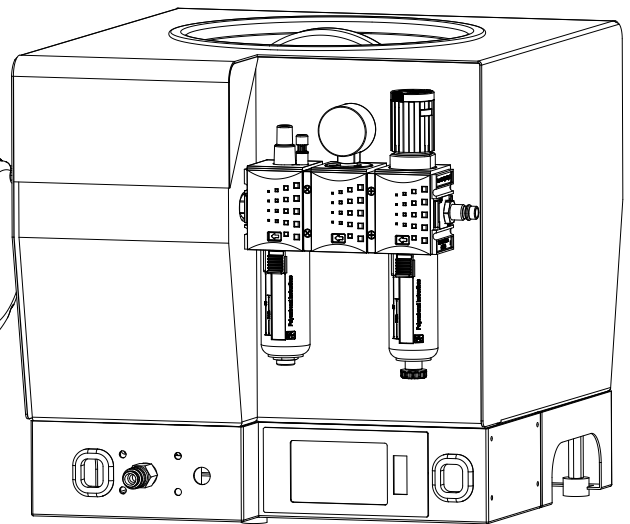

Additional feature to the DEPRAG Feed Module (DFM)

DEPRAG and Micropsi Industries present: AI-based screwdriving assembly

Micropsi Industries' control system gives robots the eye-hand coordination typical of humans thanks to AI and cameras. The AI controller takes control of the last centimeters or millimeters of the robot's movement so that it precisely finds its target position (screw position).

The intelligent screwdriving system offers many advantages:

- Compensation of position and angle tolerances
- Compensation of manufacturing tolerances in the component
- Dynamic working on a moving belt



If you would like to learn more about our intelligent screwdriving systems and their advantages, please contact us.

